

DTS-6(2) SERIES

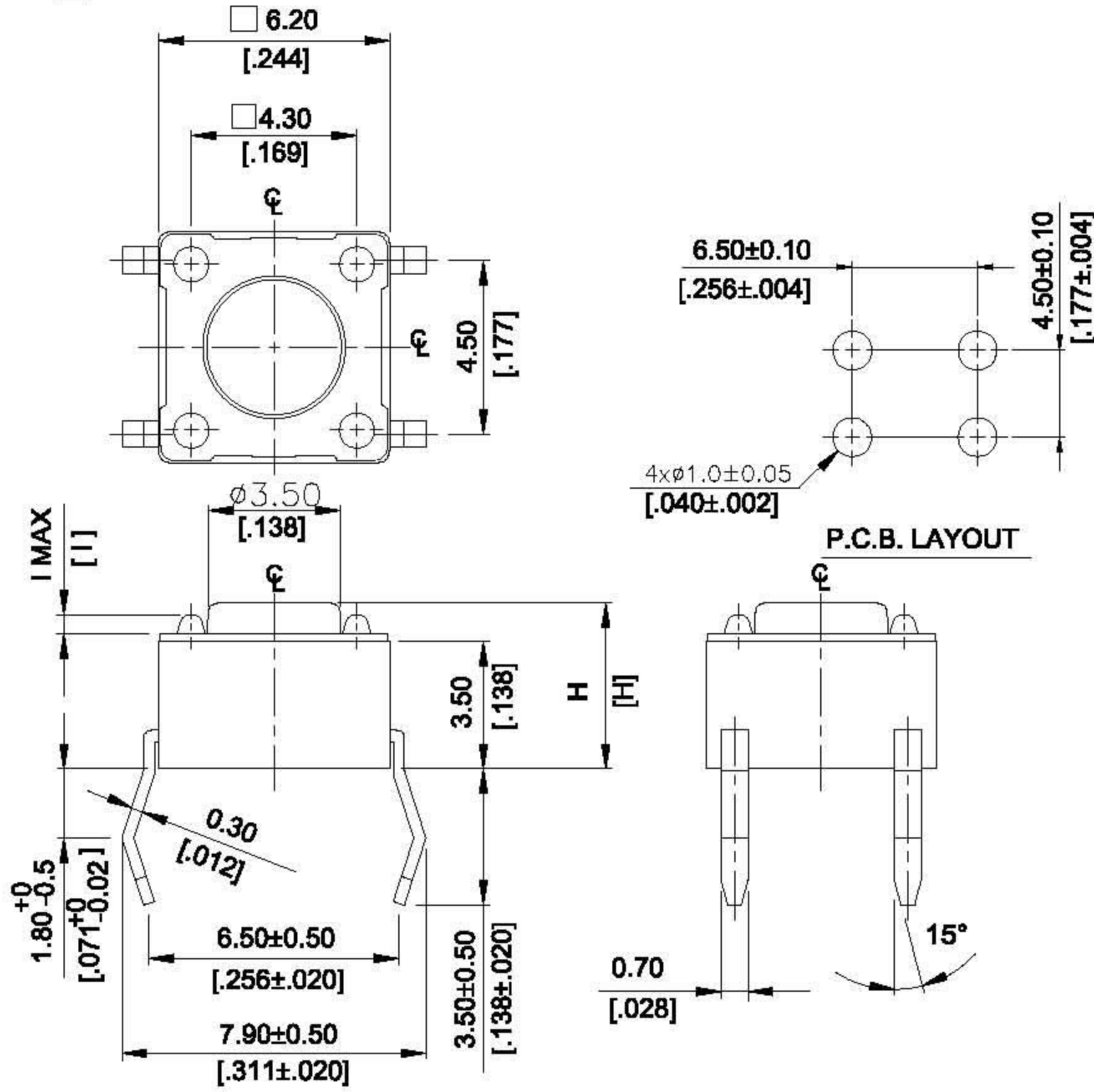

DIMENSIONS

DTS-61~66 □



PROD.	NO.	I	INCHES.
DTS-62~66 □-V		0.6 MAX	.0236 MAX
DTS-61 □-V		0.5 MAX	.0197 MAX

PROD.	NO.	H
DTS-66 □-V		13.0 [512]
DTS-65 □-V		9.5 [374]
DTS-63 □-V		7.0 [275]
DTS-62 □-V		5.0 [197]
DTS-61 □-V		4.3 [169]

General Tolerance : ±0.2mm

DTS-644、648 □

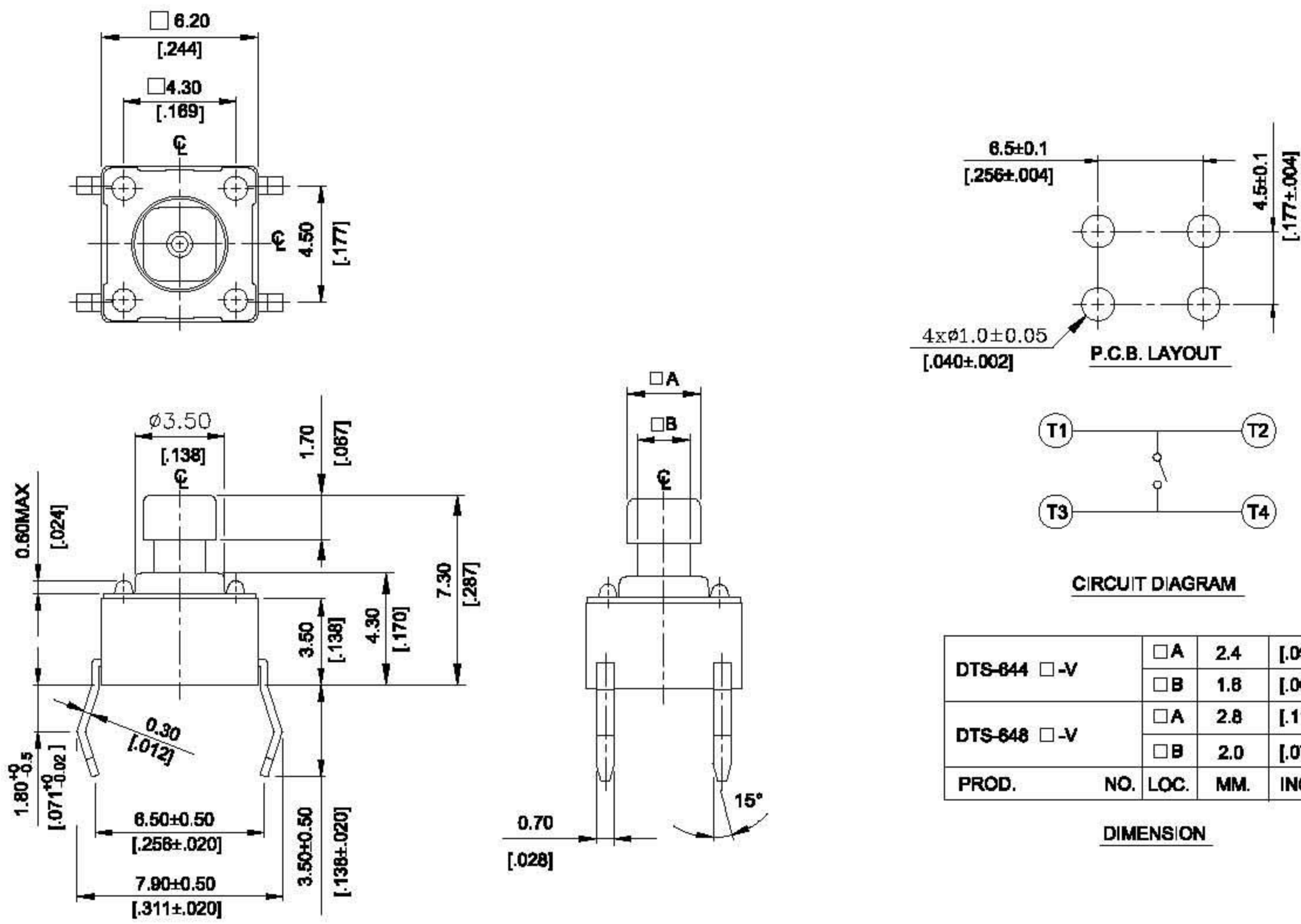

PROD.	NO.	LOC.	MM.	INCH.
DTS-644 □-V	□ A	2.4	[095]	
	□ B	1.8	[063]	
DTS-648 □-V	□ A	2.8	[110]	
	□ B	2.0	[079]	

DIMENSION

General Tolerance : ±0.2mm

DTS-21、25□

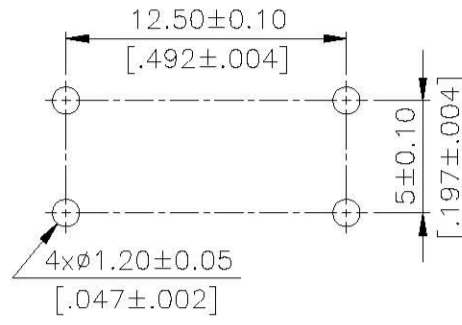
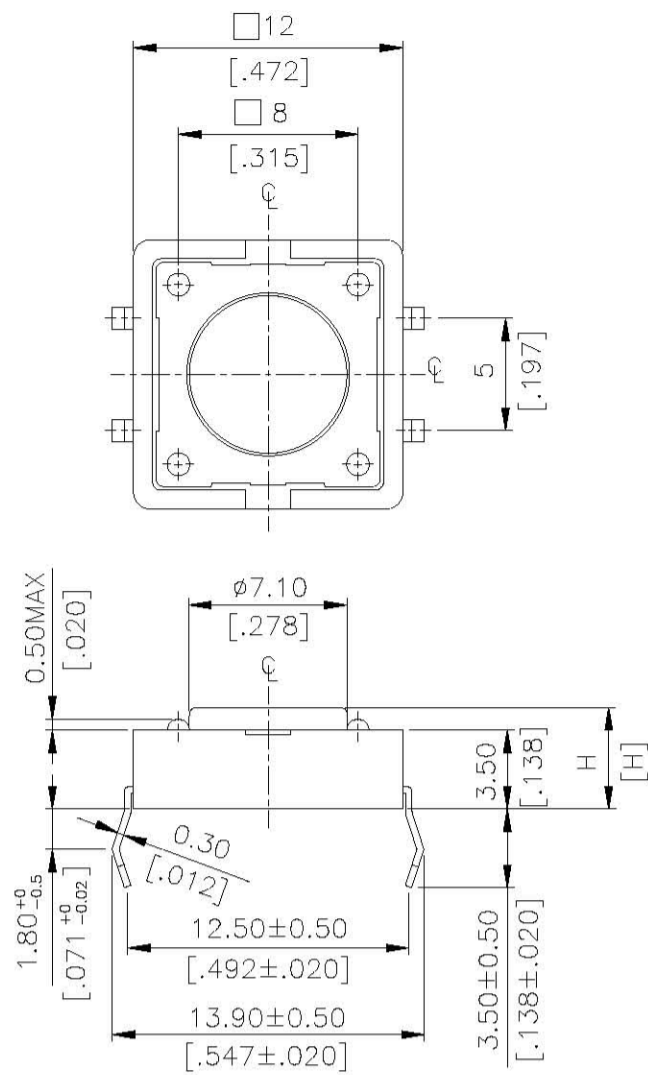

P.C.B. LAYOUT

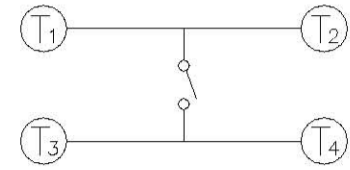

CIRCUIT DIAGRAM

DTS-25□	8.5 [0.335]
DTS-21□	4.3 [0.169]
PROD. NO.	H
附表 A	

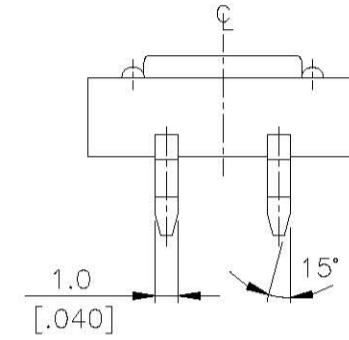

General Tolerance : $\pm 0.2\text{mm}$

DTS-24□

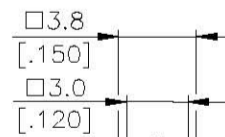
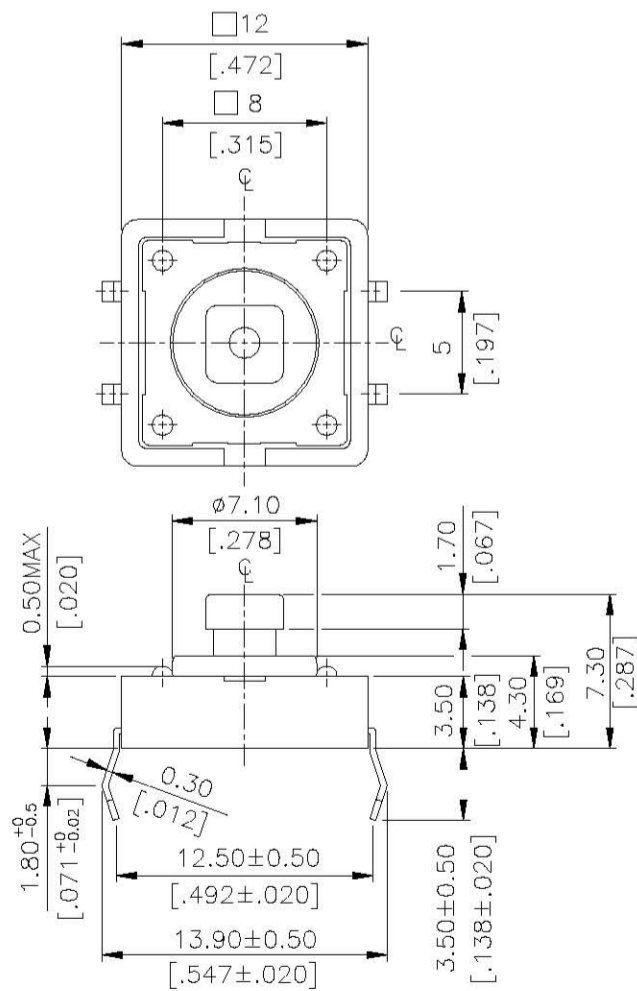

P.C.B. LAYOUT

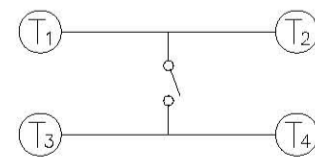
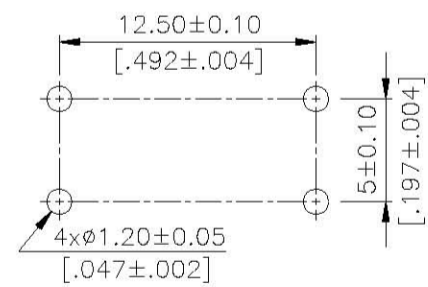

CIRCUIT DIAGRAM



General Tolerance : $\pm 0.2\text{mm}$

HOW TO ORDER

D T S □ - □ □ □ - □ - □

Package style:

- = Bulk pack
- ▲ B = Tube
- (▲ Except DTS-63、644、648、65、66)

Soldering:

- V = Lead Free Solderable

Color of stem for operating force:

- ▲ K = Black , 100gf
- N = Brown , 160gf
- R = Red , 260gf
- S = Salmon , 320gf
- ▲ Y = Yellow , 520gf
- (▲ 12x12 K、Y Unavailable)

Dimension H :

- ◎ 6 X 6 mm
- 1 = 4.3 mm
- 2 = 5.0 mm
- 3 = 7.0 mm
- 44 = 7.3 mm(SQ.)x2.4 mm
- 48 = 7.3 mm(SQ.)x2.8 mm
- 5 = 9.51 mm
- 6 = 13 mm

- ◎ 12 x 12 mm
- 1 = 4.3 mm
- 4 = 7.3 mm (SQ.) x 3.8 mm
- 5 = 8.5 mm

Prod. Size :

- 6 = 6x6 mm
- 2 = 12x12 mm

- = None Post
- ▲ = With Post
- < ▲ For 12x12 only >
- Tactile Switch

SPECIFICATION

△MECHANICAL

Operation Force:520±130gf Yellow(Y)
320±80gf Salmon(S)
260±50gf Red(R)
160±50gf Brown(N)
100±50gf Black(K)

Stop Strength: Max 3kgf vertical static load continuously for 15 seconds

Stroke : (12x12) 0.35±0.1mm
(6x6) 0.25+0.2/-0.1mm

Operation Temperature Range : -25°C to +70°C

Storage Temperature Range : -30°C to +80°C

△ELECTRICAL (6X6)

Electrical Life : 300,000 cycles for 320gf,520gf
500,000 cycles for 260gf
1,000,000 cycles for 100gf,160gf

Rating : 50mA , 12 VDC

Contact Resistance : 100mΩ max

Insulation Resistance : 100MΩ min , 500 VDC

Dielectric Strength : 250 VAC / minute

Contact Arrangement : 1 pole 1 throw

MATERIAL

△COVER : Stainless steel

△CONTACT DISC : Phosphor bronze with silver cladding

△TERMINAL : Brass with silver plated

△BASE : UL94V-0 Nylon Thermoplastic

△STEM : UL94V-0 Nylon Thermoplastic

Color : Black(100gf) , Brown(160gf) , Red(260gf)

Salmon(320gf) , Yellow(520gf)

Silicon Rubber Color : Red (300gf) [DTS-21 Only]

△ELECTRICAL (12X12)

Electrical Life: 100,000 cycles for 320gf

100,000 cycles for 260gf

200,000 cycles for 160gf

SOLDERING PROCESS

△WAVE SOLDERING: Recommended solder temperature at 500°F(260°C)max. 5 seconds subject to PBC 1.6mm thickness (For through hole type)

△Hand soldering : Use a soldering iron of 30 watts , controlled at 350°C approximately max 5 seconds while applying solder.

PACKING

Part Number	Number Per Bag	Number Per Tube
DTS-6□□□	1000	-
DTS-61	-	77
DTS-62	-	77
DTS-2	500	-
DTS-2□□	-	39
KTSC-6□□	1500	-
KTSC-2□□	500	-

DTS-61.62 TUBE

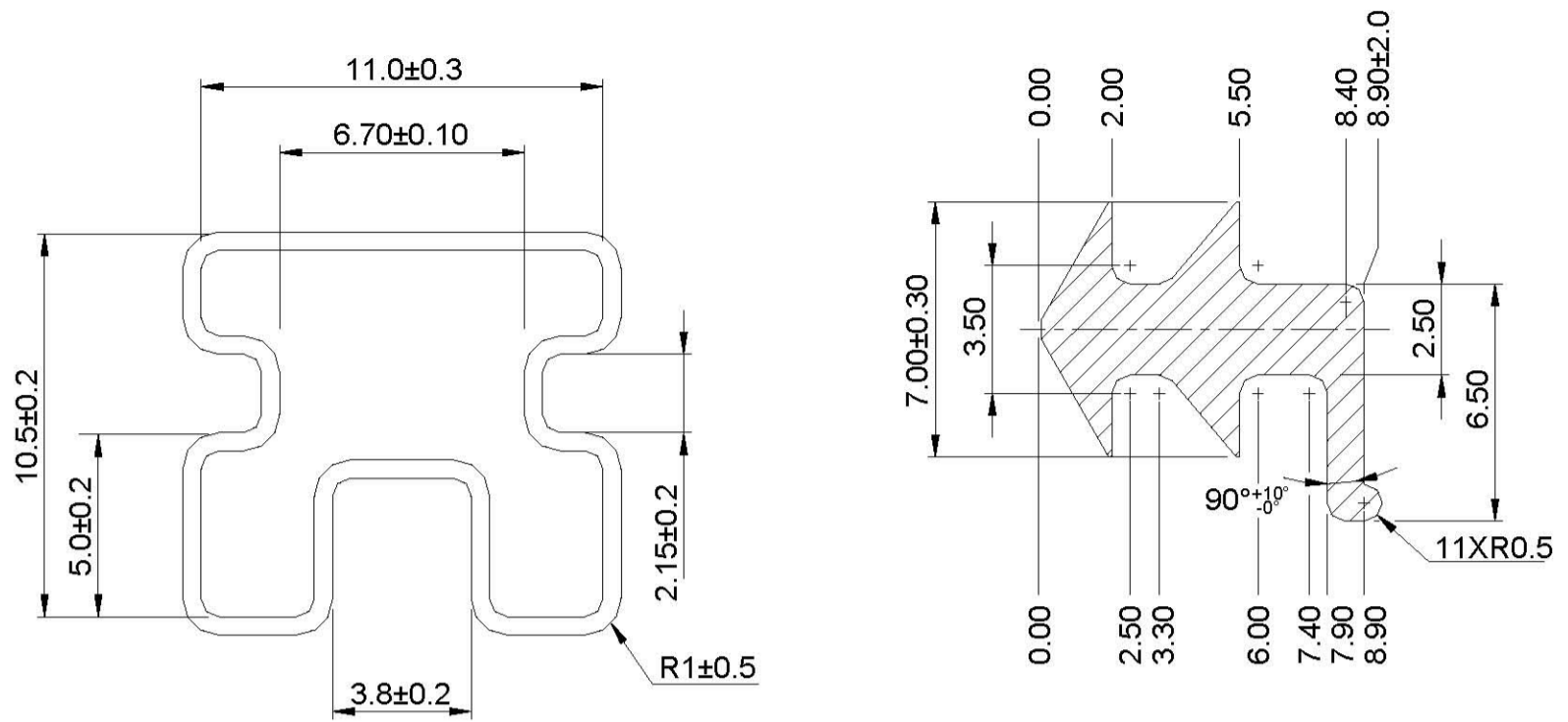

General Tolerance : $\pm 0.2\text{mm}$

DTS-2 □ □ TUBE

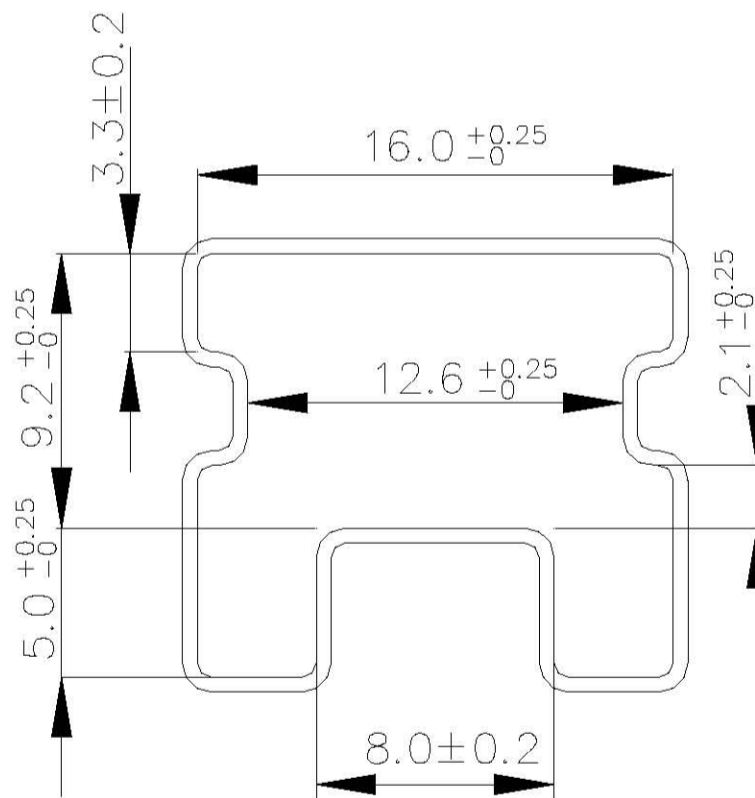

General Tolerance : $\pm 0.2\text{mm}$